



114 Solander Road Seven Hills NSW

3  1 

The glory of renting is that you get to live exactly where you want to, and this great family home is ideal for the growing family, any young couple or singles simply want to be perfectly placed for their lifestyle. Offering a simple layout, nice, open living areas and entertaining options, it also has plenty of room for storage. The spacious backyard allows the kids and pets to roam freely, and the street is family-friendly. What's more, the location, near the Kings Langley border, is extra-convenient no matter what lifestyle you're seeking.

Features:

- ? Three bedrooms, two with built-in wardrobes
- ? Neat, well-appointed gas kitchen with attractive stainless-steel appliances and plentiful preparation and storage space
- ? Open, L-shaped living/dining area

View : <https://www.agiuspropertygroup.com.au/lease/nsw/western-sydney/seven-hills/residential/house/6820494>



Piers Silingardi
0433 543 154



Adam Ruddy
0447 742 719

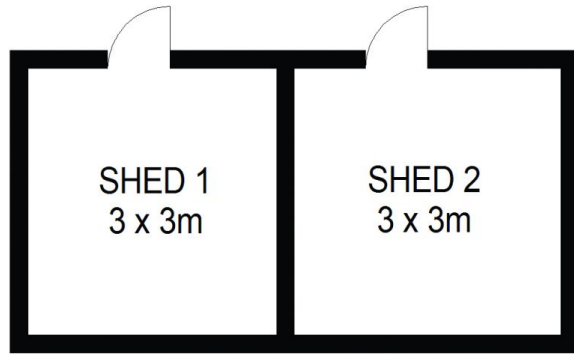

(NOT IN POSITION)



114 Solander Road
Seven Hills



DISCLAIMER: All dimensions are approximate and for illustrative purposes. Interested parties should rely on their own enquiries. Floor Plans by ShutterBooth Sydney.