



114 Solander Road Seven Hills NSW

3  1  2 

This great family home is ideal for the growing family, any young couple or singles simply want to be perfectly placed for their lifestyle. Offering a simple layout, nice, open living areas and entertaining options, it also has plenty of room for storage. The spacious backyard allows the kids and pets to roam freely, and the street is family-friendly. What's more, the location, near the Kings Langley border, is extra-convenient no matter what lifestyle you're seeking.

Features:

- ? Three bedrooms, two with built-in wardrobes
- ? Neat, well-appointed gas kitchen with attractive stainless-steel appliances and plentiful preparation and storage space
- ? Open, L-shaped living/dining area
- ? Bright family bathroom with combined shower/bath
- ? Internal laundry big enough for linen work

Price : \$ 810,000
Land Size : 689.2 sqm
View : <https://www.agiuspropertygroup.com.au/sale/nsw/western-sydney/seven-hills/residential/house/7271860>



Alistair Agius
02 8320 0598



Jonah Tuilata
0415 467 477

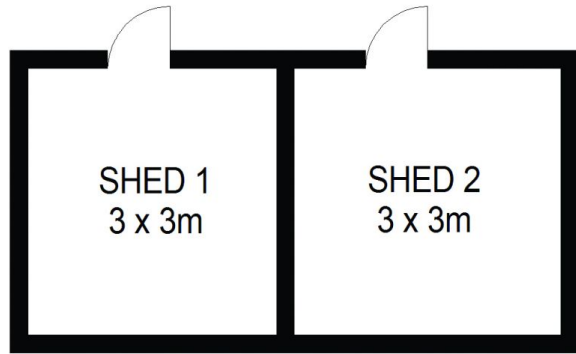

(NOT IN POSITION)

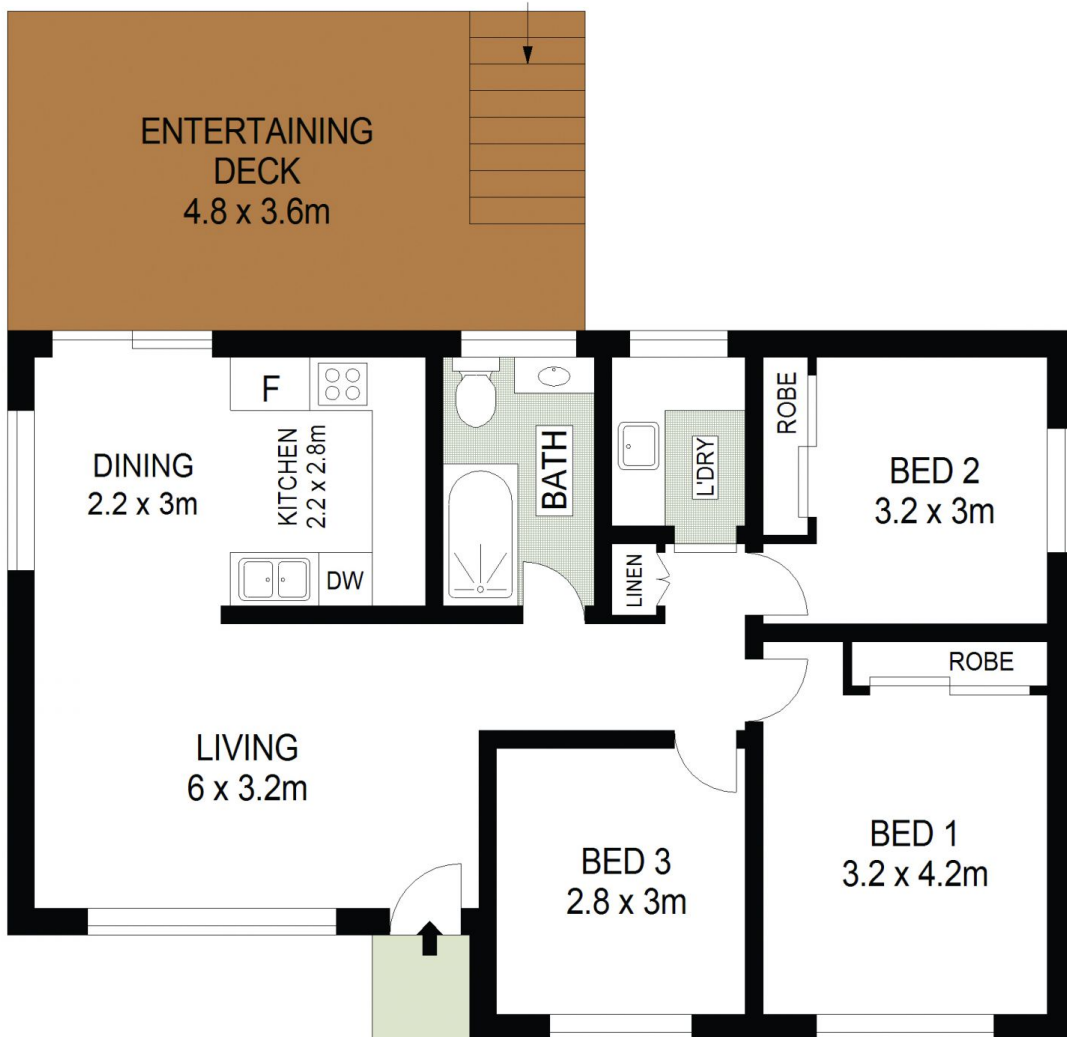

114 Solander Road
Seven Hills



DISCLAIMER: All dimensions are approximate and for illustrative purposes. Interested parties should rely on their own enquiries. Floor Plans by ShutterBooth Sydney.